

LOC	DIST	REVISIONS					
AG	53	P	LTR	DESCRIPTION	DATE	DWN	APVD
		G1		REVISED PER ECO-06-018763	07FEB07	DKH	JH

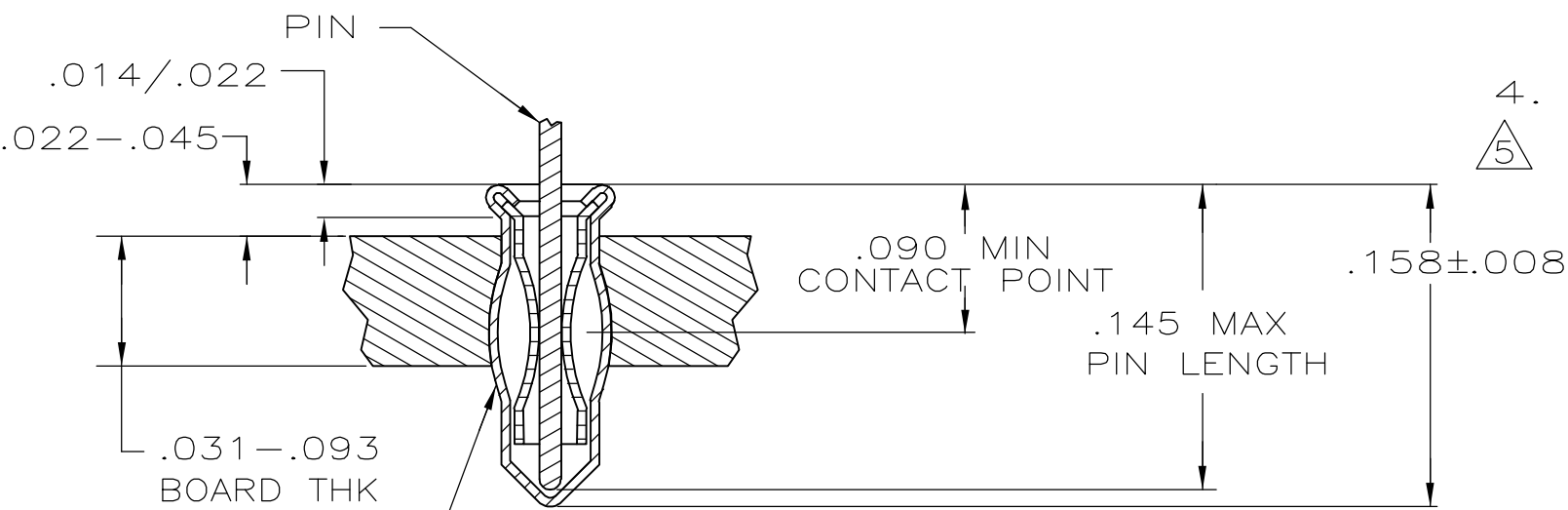
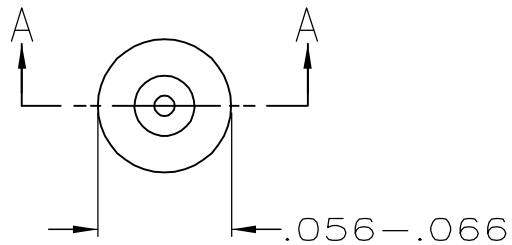

INSERTION MACHINE CAPABLE OF OVALING SOCKET FOR RETENTION IN PC BOARD WITH .042±.003 DIA HOLE PRIOR TO SOLDERING OPERATION.

SECTION A-A

1. MATERIAL:
 EYELET - COPPER (QQ-C-576)
 SPRING - BERYLLIUM COPPER (QQ-C-533)
- △2 TIN (MIL-T-10727) .000150 MIN THK
- △3 GOLD (MIL-G-45204) .000030 MIN THK OVER NICKEL (QQ-N-290) .000011 MIN THK ON CONTACT AREA.
- △4 TO INSURE 1/2 OZ MIN RETENTION DO NOT EXCEED .004 DIFFERENCE IN PIN DIA WHEN CHANGING TO A SMALLER DIA PIN
4. HOLE SIZE FOR HAND INSERTION 0.043-0.046
- △5 TIN-LEAD PLATE .000150 MIN. THK.

OBSOLETE
OBSOLETE

.090/.145	.015/.021	GOLD △3	△5	645945-7
.090/.145	.012/.018	GOLD △3	△2	645945-5
		TIN △2		645945-4
	.015/.021	GOLD △3	△2	645945-2
		TIN △2		645945-1
LENGTH	DIA △3	SPRING	EYELET	PART NO
PIN		FINISH		
NO. 1 SERIES SHORT				

THIS DRAWING IS A CONTROLLED DOCUMENT.		DWN M. BOWERS 12-10-82	AMP Incorporated Harrisburg, PA 17105-3608	
DIMENSIONS: INCHES		CHK P. MUTZABAUGH 6-10-85	NAME MINIATURE SPRING SOCKET ASSEMBLY	
TOLERANCES UNLESS OTHERWISE SPECIFIED: 0 PLC ±- 1 PLC ±- 2 PLC ±- 3 PLC ±- 4 PLC ±- ANGLES ±-		APVD G.D. MILLER 6-10-85	PRODUCT SPEC -	
MATERIAL -		FINISH -	APPLICATION SPEC -	RESTRICTED TO -
		WEIGHT -	SIZE A3	CAGE CODE 00779
		CUSTOMER DRAWING	DRAWING NO C- 645945	REV G1
		SCALE NTS	SHEET 1 OF 1	